

profiline
plastic pipe extrusion

Extrusion lines for winding pipe technology





The product application

First of all we at **bauku** always look at the product application before we look at the machinery to produce the pipe systems. The list of possible applications is long as we are able to tailor-make the plastic pipes according to the needs.

Even though our extrusion lines are flexible in choice of diameter range and profiles, we have four different series depending on the main product application the customer is looking for.



Water technology

Drinking water storage and supply, rainwater transport, sea water intake and outtake pipelines.



Sewer technology

Storm water retention tanks, sewer pipelines, pipelines in treatment plants, discharge and overflow manholes.



Industry technology

Tanks for the storage of chemicals, air-condition pipes, underground safety tanks, pipelines, manholes with valves.



Landfill technology

Drainage pipes in the waste, telescopic manholes, manhole towers, gas collection stations, leakage water tanks.

- 1 Drinking water storage tank DN 2300, underground installation, with entry shaft DN 1200, length 18 m, storage volume 74 m³.
- 2 Sewage storm water retention tank DN 2500, length 35 m, with central overflow structure DN 3000, tangential entry shafts DN 1200, storage volume 171 m³.

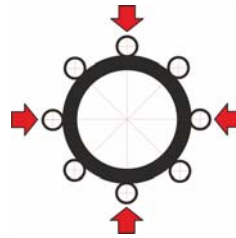

High outside loads

These pipes need a high ring stiffness and a profiled wall construction to combine a high stability with a low weight. The **profilline p-series** is the first choice in this case. The **profilline c-series** might be an interesting complement.



High inside load

These pipes need a high inside pressure resistance and a solid wall construction with a fiber or steel layer to combine a high stability with a low weight. The **profilline s-series** and **f-series** are the first choice in this case.



3



4

The innovation

Founded in the year 1956, **bauku** is the most experienced producer for profiled plastic pipes worldwide. From the very beginning, **bauku** was using the own machinery technology to produce and to sell plastic pipe systems for the German Market. Up to now we created more than 30 patents, proving that we are number one in innovation for the winded extrusion pipe. The diameter range of our machines starts at 300 mm and ends at 5000 mm inner diameter.

- 4 **profilline p-series** with mandrel DN 3000
- 5 German patent for spiral winding process
- 6 Drawing under German Patent for spiral winding
- 7 Australian Patent for profiled pipe wall
- 8 Drawing under Australian Patent for profile
- 9 USA Patent for leakage inspection
- 10 Drawing under USA Patent for leakage detection
- 11 Japanese Patent registration

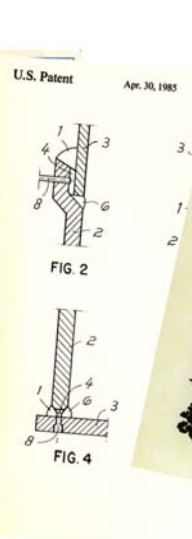
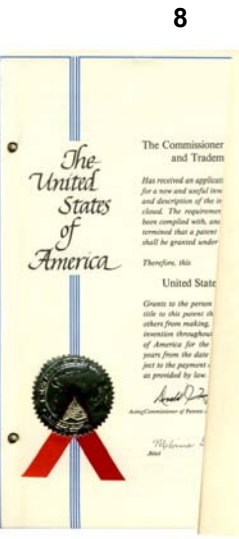
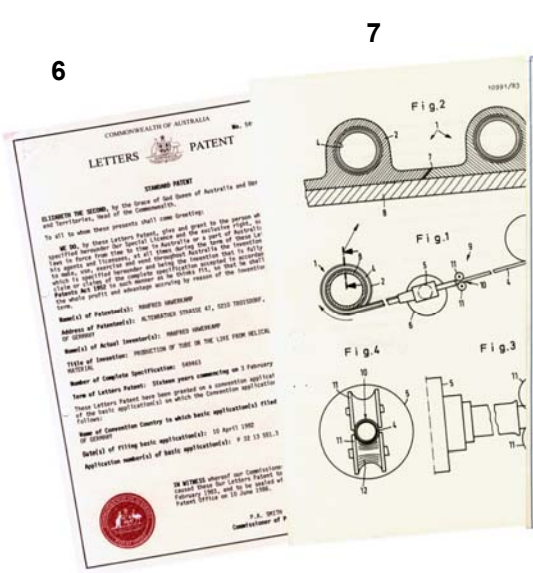
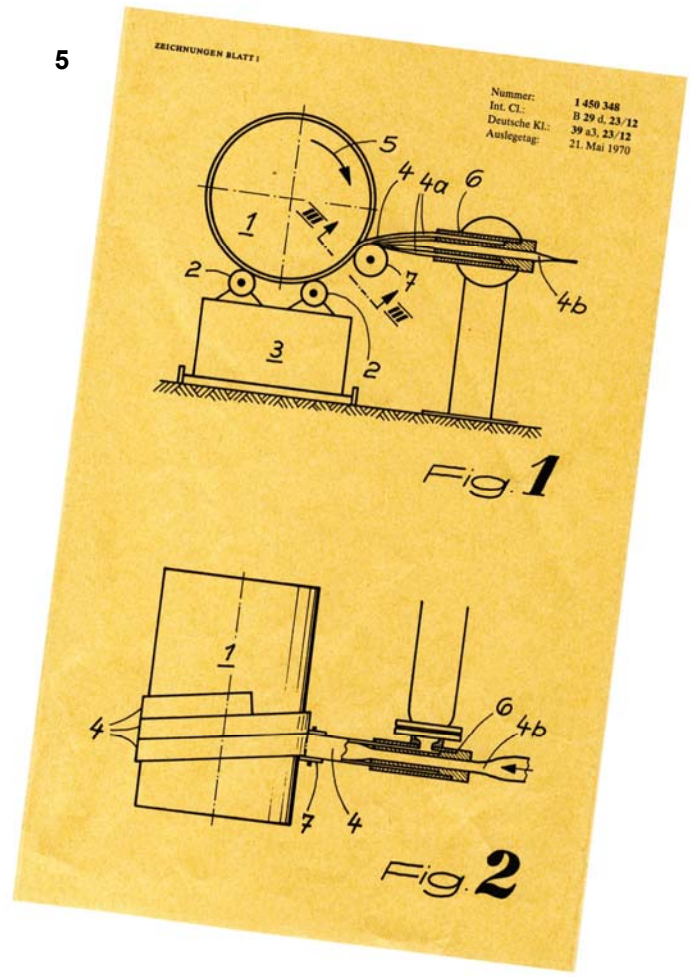

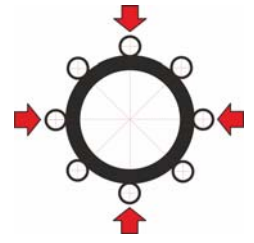

extrusion lines for high ring stiffness pipes



11

The **bauku twin-head technology** enables running a highly flexible production. The machinery can switch from a square profile to a round profile extrusion within just a few minutes. By adding more layers and by changing the wall thickness and profile distance, the number of possible wall structures is nearly unlimited.

- 11 **profilline p-series** with mandrel DN 3400 and profile pipe made from modern PP with socket and spigot end for extrusion weld joint
- 12 Die head "round" with extrusion of the second profile layer, modern PP
- 13 Twin-head technology, sketch of general design



12

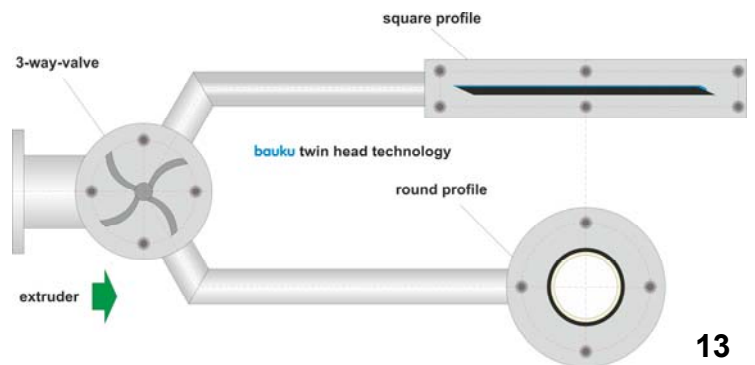

13

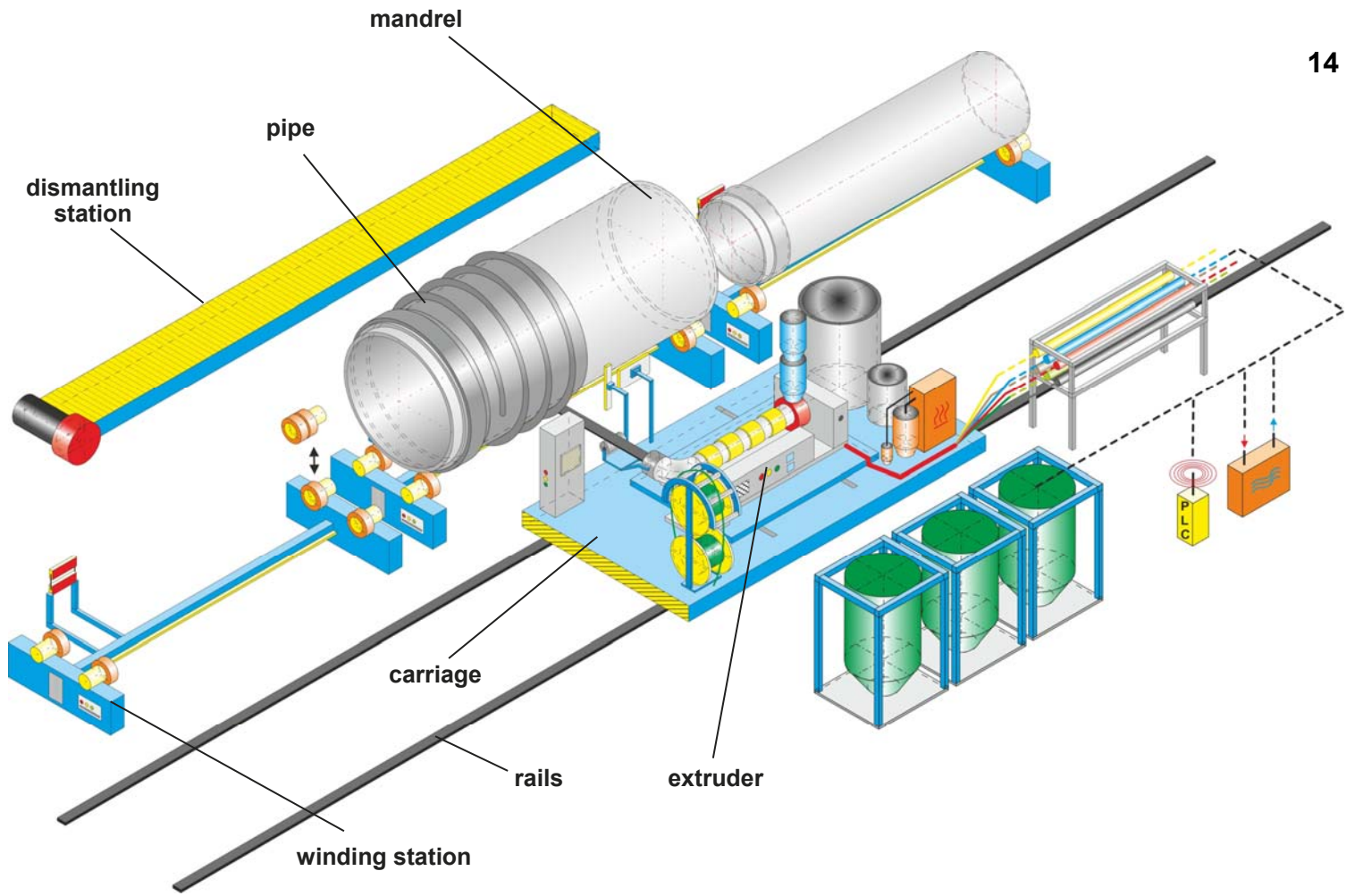

Production method

The profile is extruded with 200° C and is guided directly onto the surface of a steel mandrel. The mandrel is turning around at the winding station and the extruder passes the station on a rail system. This movement results in a spiral winding process, where the profiles are overlapping and melting, as the material still has a temperature of 200° C. Once the extrusion for a 6 m pipe is finished, the product is cooling down, while the extruder is starting at the next winding station.

After the cooling process, the mandrel is folded down and extracted from the pipe, then folded up again and is returning to the winding station for the next production sequence.

- 14 Sketch of **p-series** with three winding stations
- 15 Sketch of typical profile for sewer pipes, smooth inside wall and profiled outside wall
- 16 Transport of a mandrel DN 3500 in a double crane, the mandrel is moved from the storage to the winding station

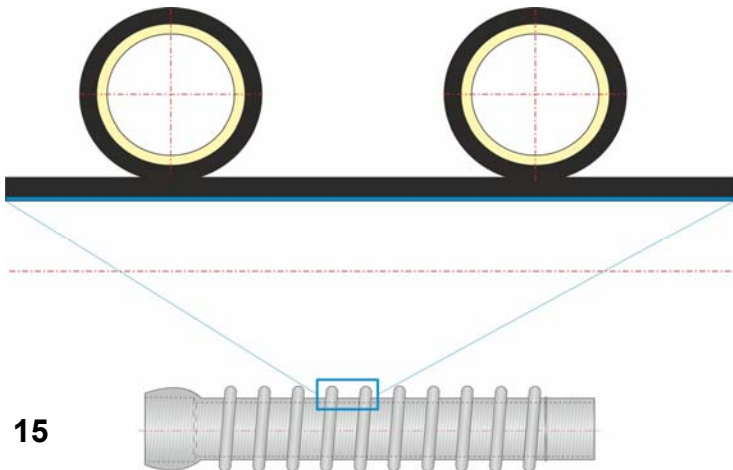

15



16

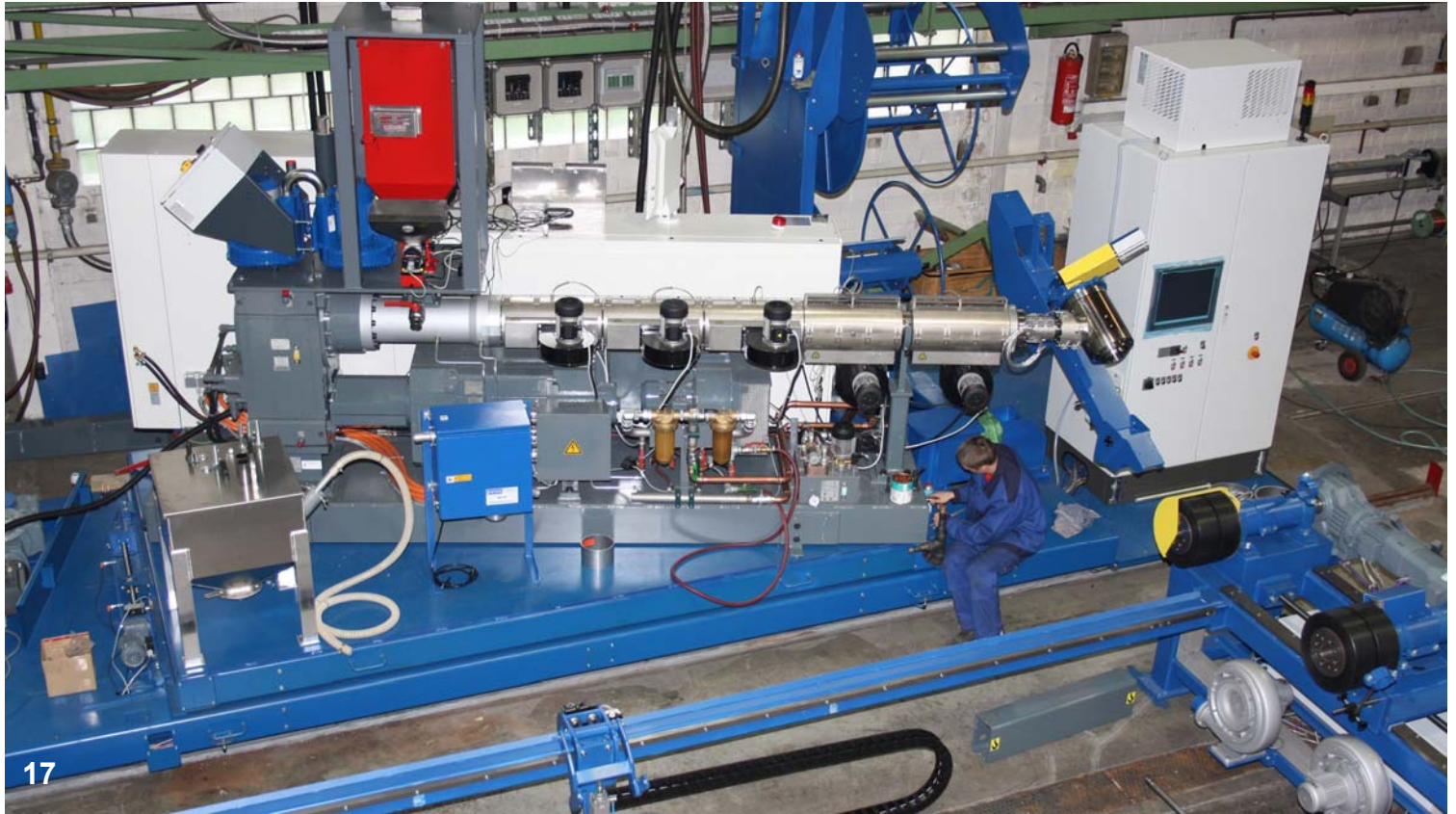

17



18



19

All extrusion lines are installed and tested in our factory first and the customer has the chance for a first inspection. Afterwards the equipment is dismantled and shipped to the customer.

- 17 Cable installation for extruder controls
- 18 Main extruder and co-extruder as hopper version
- 19 Installation of a screw in the main extruder
- 20 Acceptance test with customer, hand-over of machinery

Diameter range DN 300 to DN 5000

Pipe length 1,5 m to 6 m

Stiffness values SN 2 to SN 75

Ouput capacity up to 1000 kg/h

Resin: modern PP or PE100



20

bauku profilline

c-series

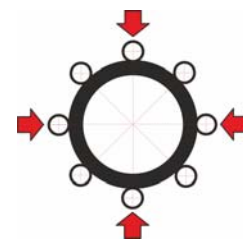

extrusion lines for core tube

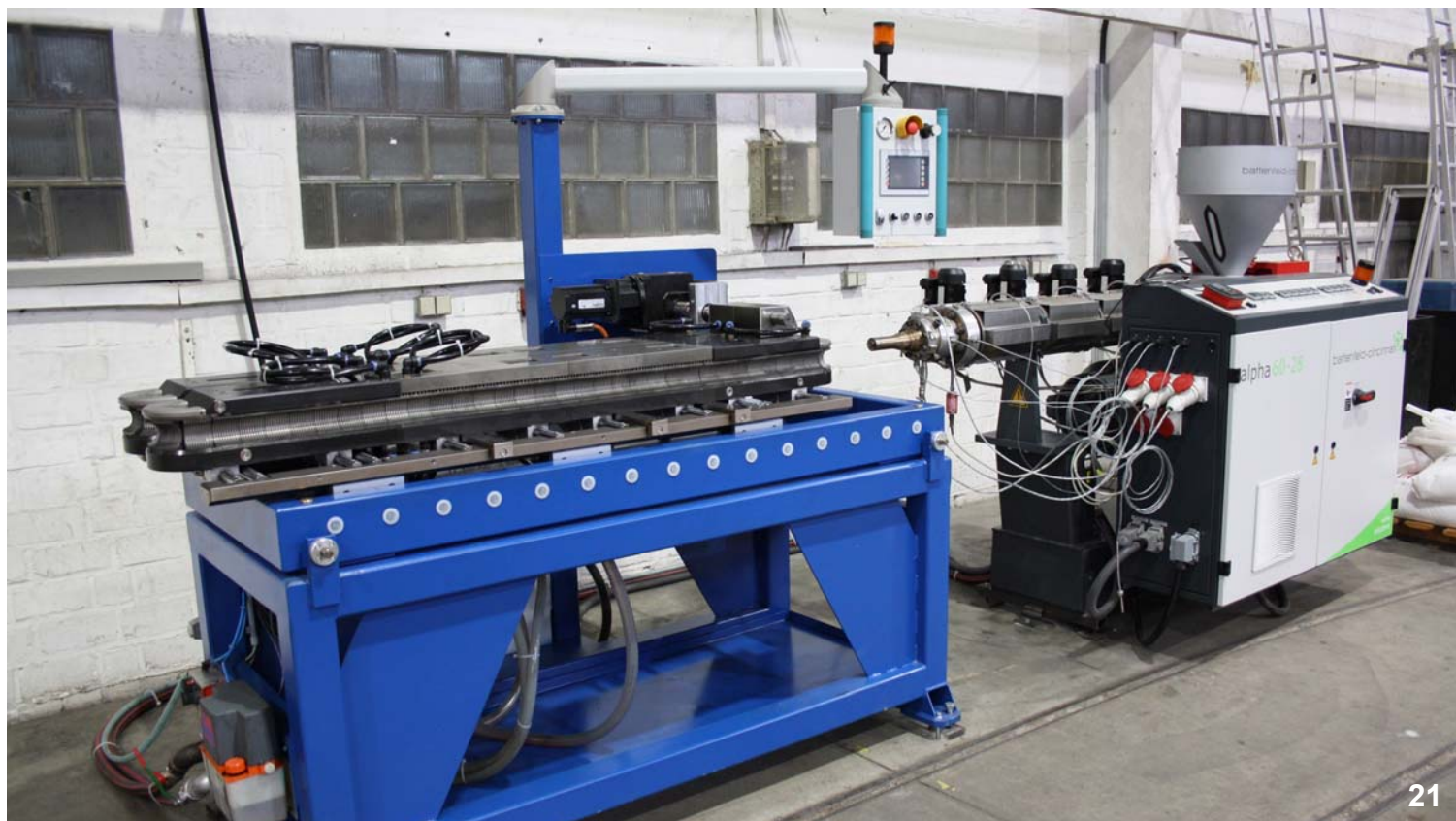

21

The core tube is used for the **profilline p-series**, where it is guided into the extruder die head and is surrounded by the extruded PP or PE.

20 Corrugator with extruder and mold blocks core tube 80
21 Double winder for the extruded core tube, core tube type 80 is in operation



22

Diameter range OD 31 to OD 97

Pipe length up to 750 m

Stiffness values SN 12 to SN 160

Output capacity up to 80 kg/h

Resin: modern PP



extrusion lines for high inside pressure pipes



The die head for the composite pipe is able to include glass fiber or steel wire in the extruded PE100 profile. The fiber (steel) is increasing the pressure resistance of the pipe and at the same time it is saving up to 50 % material.

- 23 DN 3000, first solid wall layer, thickness 10 mm
- 24 DN 800, first layer with glass fiber has been placed before, second layer is added now
- 25 Principle of the die head for the composite pipe

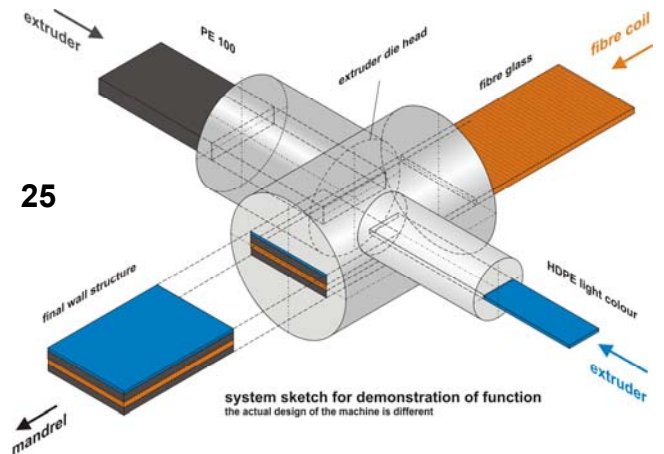
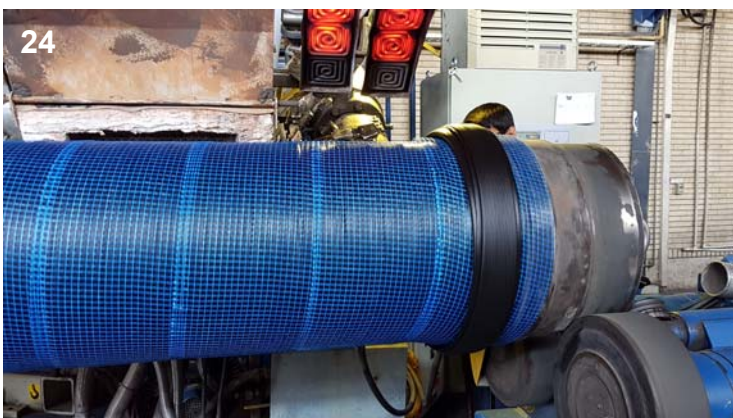

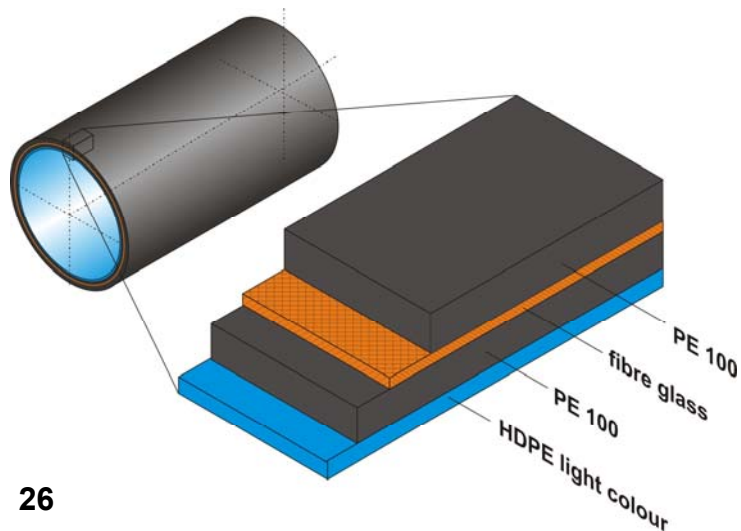

26

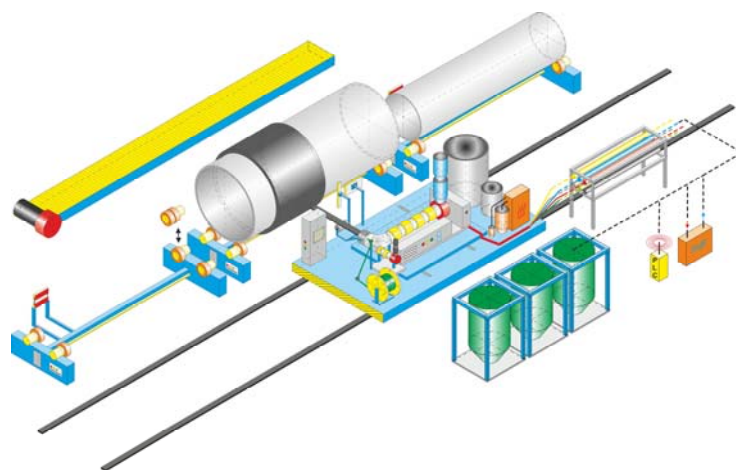

27



28

Production method

The general winding process is similar to the one described for the **profilline p-series**. However the **s-series** is just equipped with a single die head for the square profile. The maximum profile in one pass is approx. 200 mm x 10 mm. For the first layer an additional co-extrusion layer with another color can be included. In addition the operator can include a fiber inside the profile or a steel wire (depending on the customer's request). The carriage with the extruder is running forward and backwards at the winding station to increase the number of layers (and wall thickness).

- 26 Principle of wall cross section
- 27 General layout of extrusion line with three winding stations (similar to p-series)
- 28 DN 3000, PP solid wall pipe, length 5 m

Diameter range DN 800 to DN 4000

Pipe length 1,5 m to 6 m

Pressure class SDR 33 to SDR 11

Output capacity up to 1000 kg/h

Resin: PE100 or PP + fiber or steel



extrusion lines for high inside pressure fittings

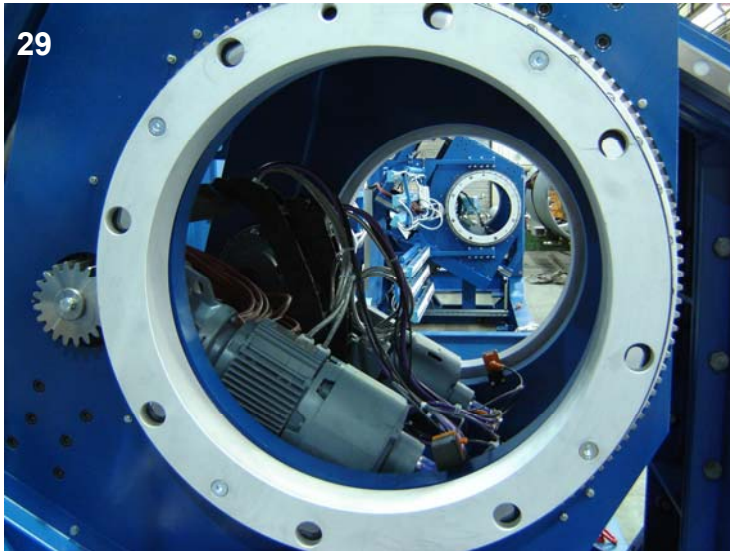

Production method

The basic winding process is similar to the one described for the **s-series**, but the **f-series** is just using mandrels with a length of 2 m. On the other hand, on two double winding stations a total of four mandrels can be put into operation without a change of tools, creating a high speed process for fittings. The size of the mandrels (diameter) can be different at each position, as the extrusion line is highly flexible and can produce different fitting diameters, wall thickness and surface design without a change of tools.

The mandrels are folded on the stations and the fittings are dismantled there. It is not necessary to transport the mandrels with the fittings to a separate dismantling station.

The extrusion line can be equipped with the same die head design as the **s-series**.

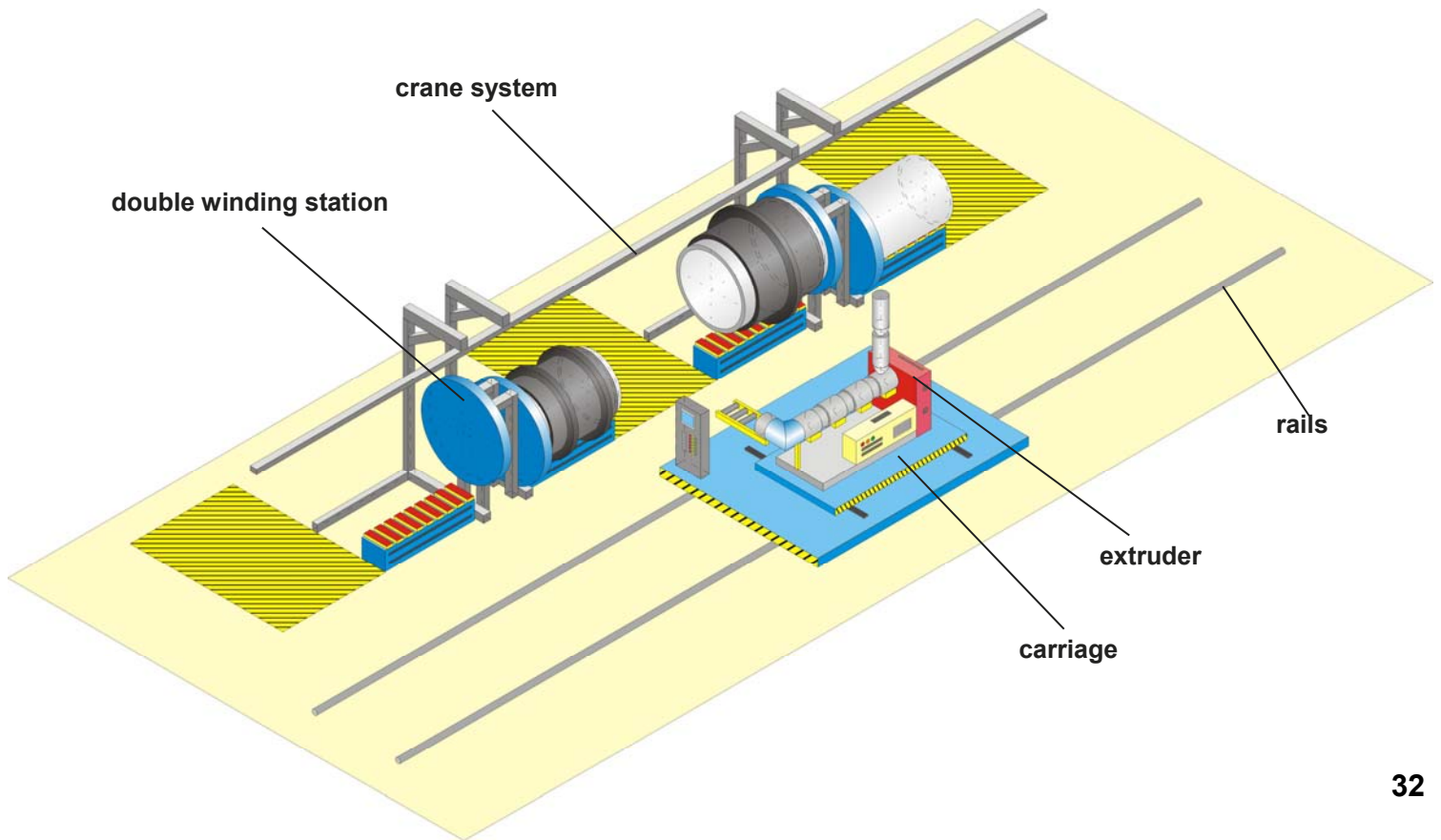

32

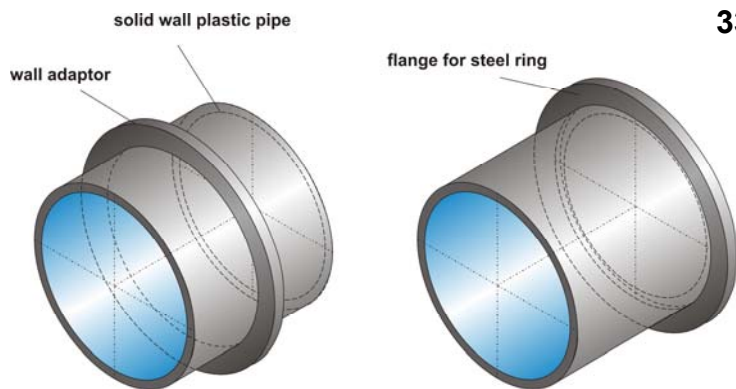

33



34

- 29 Double winder, fixing ring for mandrel
- 30 Double winder with crane and infrared heating panels
- 31 Main control cabinet on carriage
- 32 General design of extrusion line with two double winders
- 33 Typical fittings like stub ends and wall adaptors
- 34 OD 800, pipe with hubs for stub ends, SDR 33

The mandrels can be delivered either for the internal measuring system (DN) or the external measuring system (OD) depending on the standard of the pipes they should match. The **f-series** can be delivered in two sizes, the **f-500** for small diameters and the **f-1000** for large diameters.

Diameter range OD 355 to DN 2400

fitting length 0,5 m to 2 m

Pressure class SDR 17 to SDR 11

Ouput capacity up to 400 kg/h

Resin: PE100 or PP



The success

When bauku started not only to produce plastic pipe systems, but also to develop and to produce machinery lines for the unique profile extrusion process in 1972, this was the beginning of a successful story. In many countries all over the world there was a serious interest in the high quality products, as the environmental problems were similar to the ones in Germany.

From the very beginning bauku decided to enter the foreign markets step by step choosing the customers for the machinery lines very carefully. The aim was not selling as much extrusion lines as possible, but having long term relationships with partners transferring the necessary know-how for both, production technology and product technology.



埋立地内雨水排水工事(兵庫県)



北陸新幹線車輛基地建設工事(長野県)



用水環境整備工事(愛知県)



産業廃棄物最終処分場建設工事(長野県)



埋立地内雨水排水工事(兵庫県)

耐圧強度が高い。

管強度は、あらゆる分野の用途に適合できるように設計されています。ダイフラハウエル管は、耐圧強度により1種・2種・3種に区別されています。耐用年数が長く、非常に経済的です。

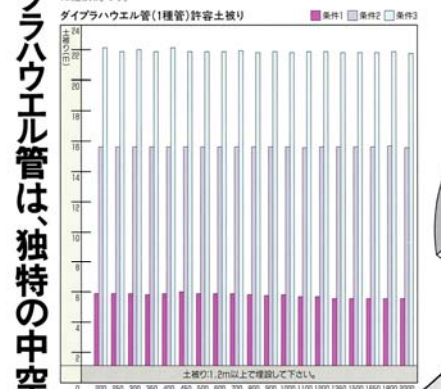

項目	条件1	条件2	条件3
標準管外径 (φ)	100	150	200
標準管内径 (φ)	75	100	125
管壁厚 (mm)	1.00	1.00	1.00
管底傾斜 (‰)	-0.20	-0.10	-0.10
土の単位体積重量 γ (kN/m³)	1.80	1.80	1.80
土の内摩擦角 φ (°)	30	30	30
土の流動摩擦係数 E (kg/cm²)	20	20	20
管底面による摩擦係数 μ ₀	0.300	0.300	0.300
土の流動摩擦係数 μ ₀	1.5	1.2	1.2

ダイフラハウエル管は、独特の中空リップ構造。

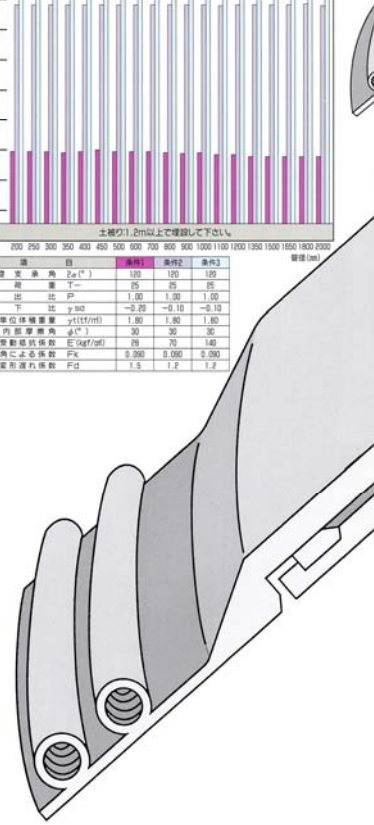

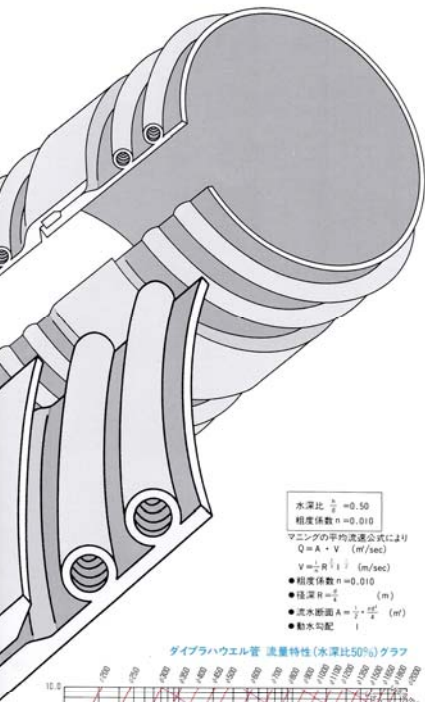
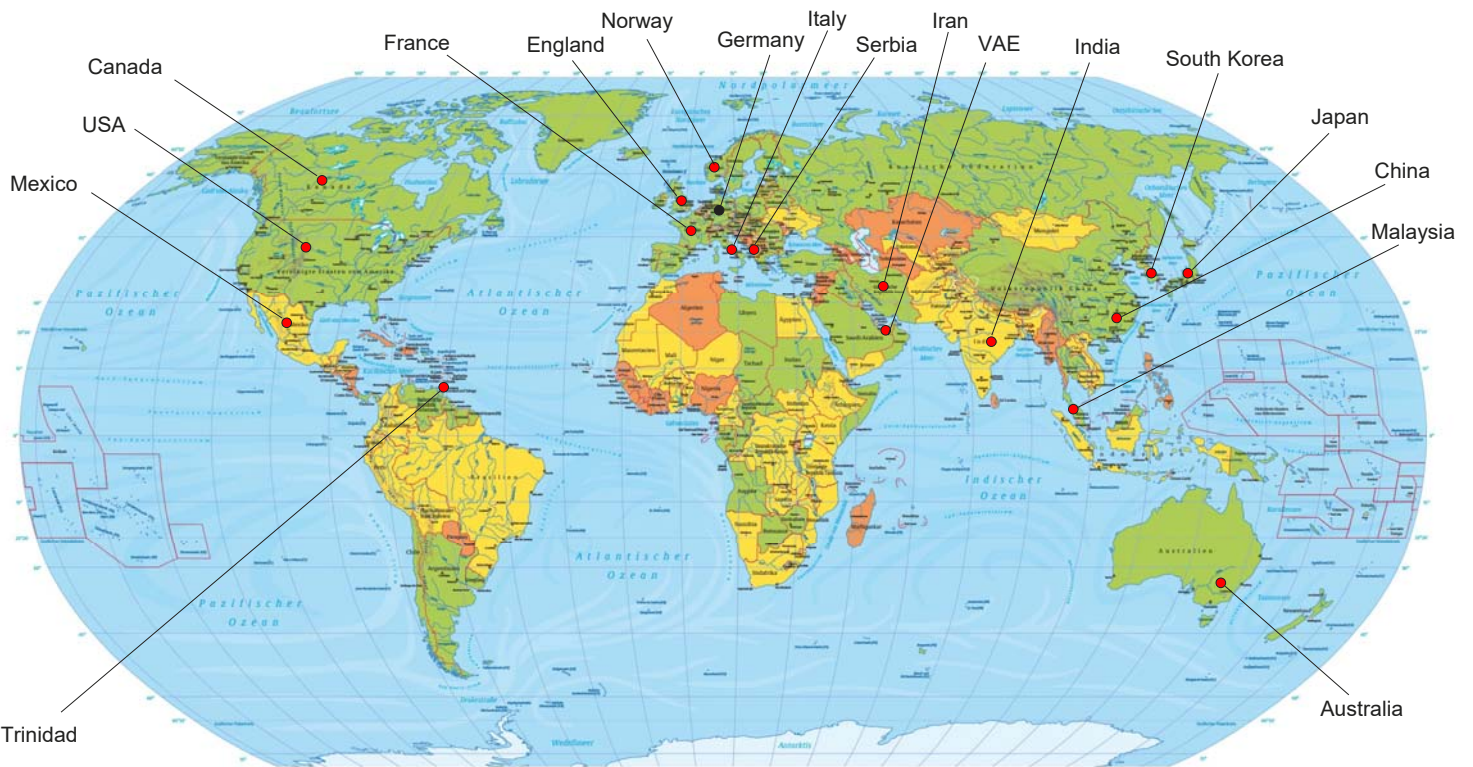

水深比 $\frac{h}{D} = 0.50$
 粗度係数 $n = 0.010$
 マニングの平均流速公式により
 $Q = A \cdot V$ (m³/sec)
 $V = \frac{R^{2/3}}{n} \cdot S^{1/2}$ (m/sec)
 ● 粗度係数 $n = 0.010$
 ● 水深 $H = \frac{D}{2}$ (m)
 ● 流水断面 $A = \frac{\pi}{4} D^2$ (m²)
 ● 配水勾配 I

ダイプラハウエル管 流量特性(水深比50%)グラフ

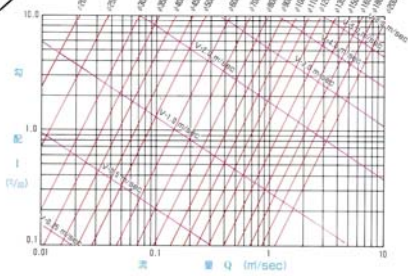

内面平滑で流量特性に、優れる。

内面がなめらかで、粗度係数は0.010と低く、流量特性にも優れています。このため、他種管と比べ、ダイプラハウエル管なら、ひとまわり小さい口径のものを採用できます。また、右設勾配も緩和できます。



排水施設設置工事(茨城県)



道路維持工事(広島県)



ゴルフ場排水管改修工事(千葉県)



国道改良工事(鹿児島県)

Today the profiled plastic pipes invented by bauku are available in many countries all over the world, even though the company name and the brand name of the product may be different. Our customers are selling the pipe systems as "spiral", "black brute", "performance pipe" or using other brand names - however it is always the bauku technology and quality that is behind the scenes.

We meet potential customers at the trade fair IFAT in Munich or the "K" in Düsseldorf, Germany, but we also attend on trade fairs in foreign countries. A full range of products, services and know-how is available and makes it worth to discover the bauku world.



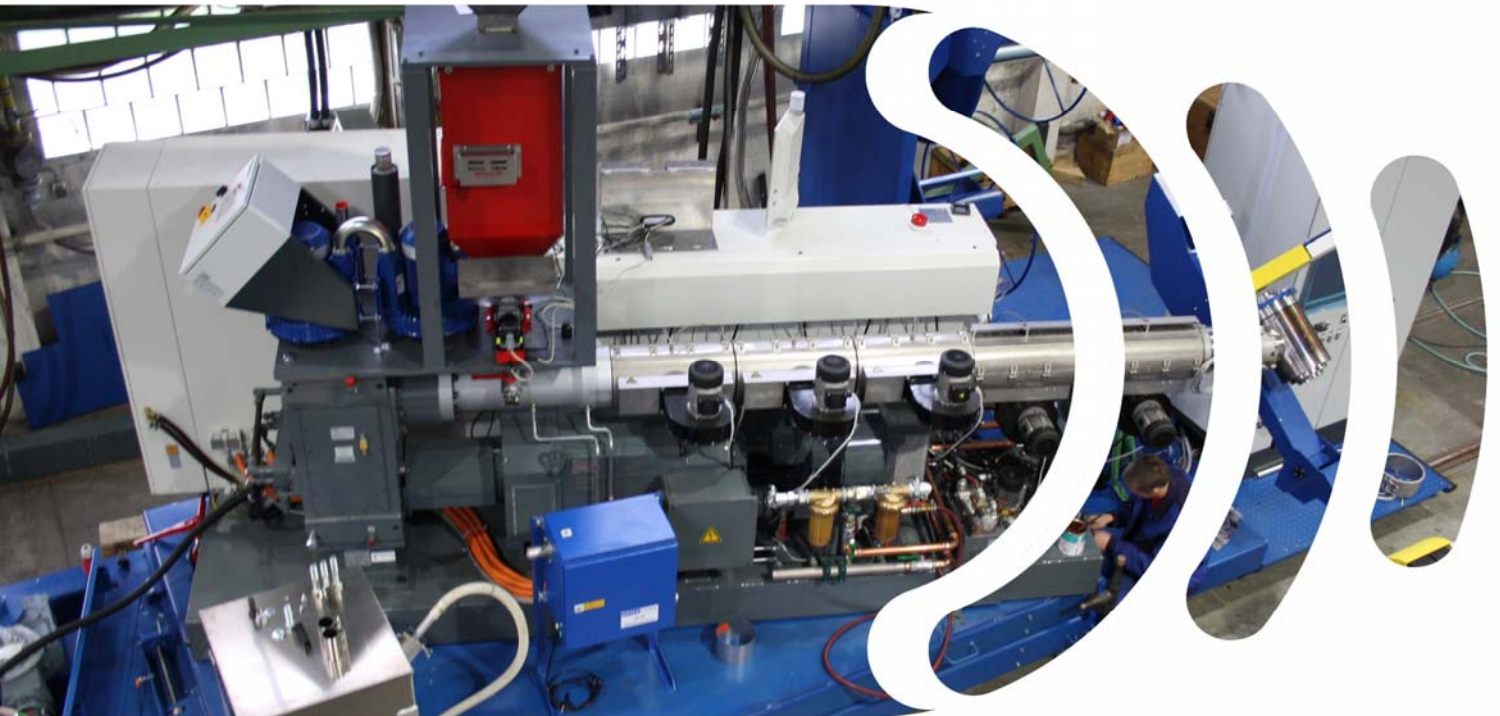

bauku extrusion technology

Gerberstrasse 41, 51789 Lindlar, Germany



+49(0)2261-9183-0
+49(0)2261-9183-21

info@bauku.com

www.bauku.com

www.facebook.com/bauku.extrusion

bauku extrusion technology